

REVISION HISTORY			
REV	DESCRIPTION	DATE	APPROVED
1		11/14/2011	

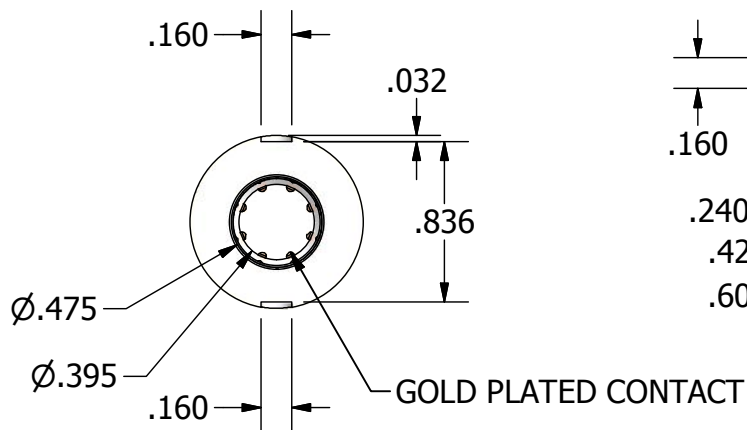
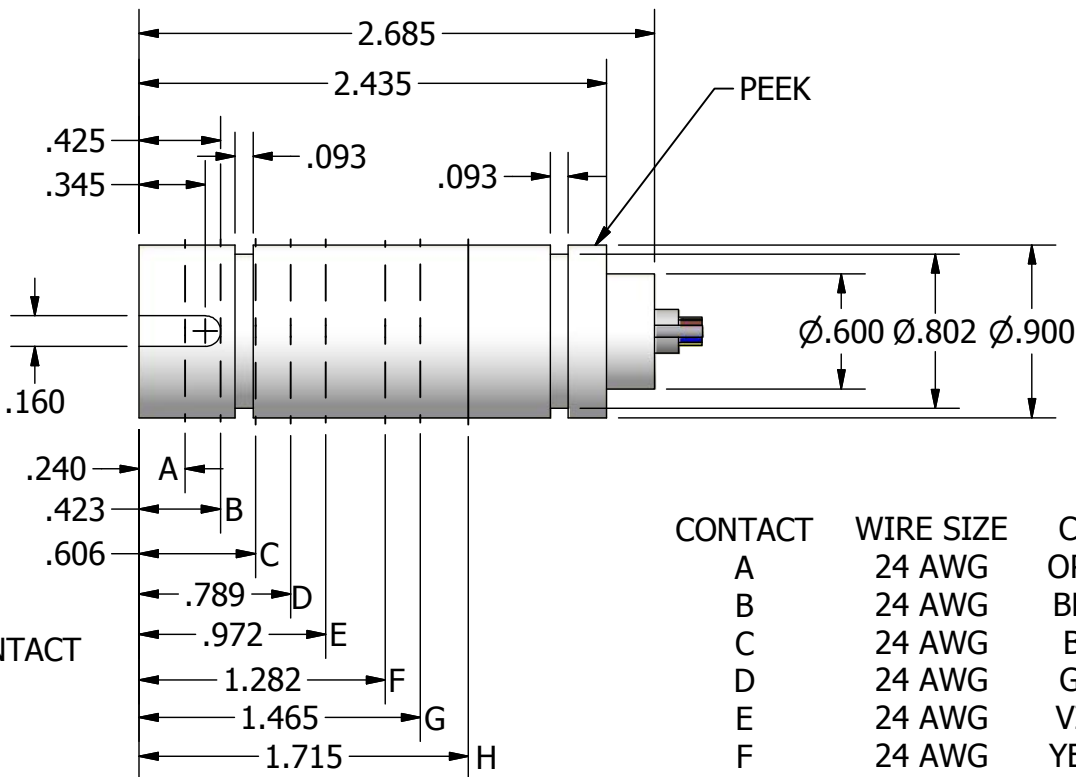

WIRING DIAGRAM

NOTES:

- TEMPERATURE RATING: 392°F (200°C)
- WIRE LEADS TO BE 24" MINIMUM FLYING LEADS FROM END OF CONNECTOR OR AS DETERMINED BY CUSTOMER.
- CONTACTS ARE GOLD PLATED PER MIL-G-45204C, TYPE I OR II, GRADE C OR D, CLASS 1 OVER NICKEL PER QQ-N-290A, CLASS 1, GRADE G.

DRAWN SISELT	11/14/2011
CHECKED	
APPROVED	
UNLESS OTHERWISE SPECIFIED: DIMENSIONS ARE IN INCHES [MM] TOLERANCES: ANGULAR: ±.50° TWO PLACE DECIMAL ±.015 THREE PLACE DECIMAL ±.005 FOUR PLACE DECIMAL ±.0005 FILLET: R.032 MAX REMOVE ALL BURRS AND BREAK SHARP EDGES .015 MAX	



TITLE			
8-CONDUCTOR, FEMALE-STEPPED			
SIZE	MATERIAL	DWG NO	REV
A	915-0250-02	915-0250-02 SALES	1

All rights reserved. This document and the information contained herein are the sole property of Canyon Manufacturing Inc. Any reproduction or distribution in whole or in part without written permission of Canyon Manufacturing Inc. is prohibited.