

REVISION HISTORY			
REV	DESCRIPTION	DATE	APPROVED
A	RELEASE TO PRODUCTION	11/9/2011	PBALCOM

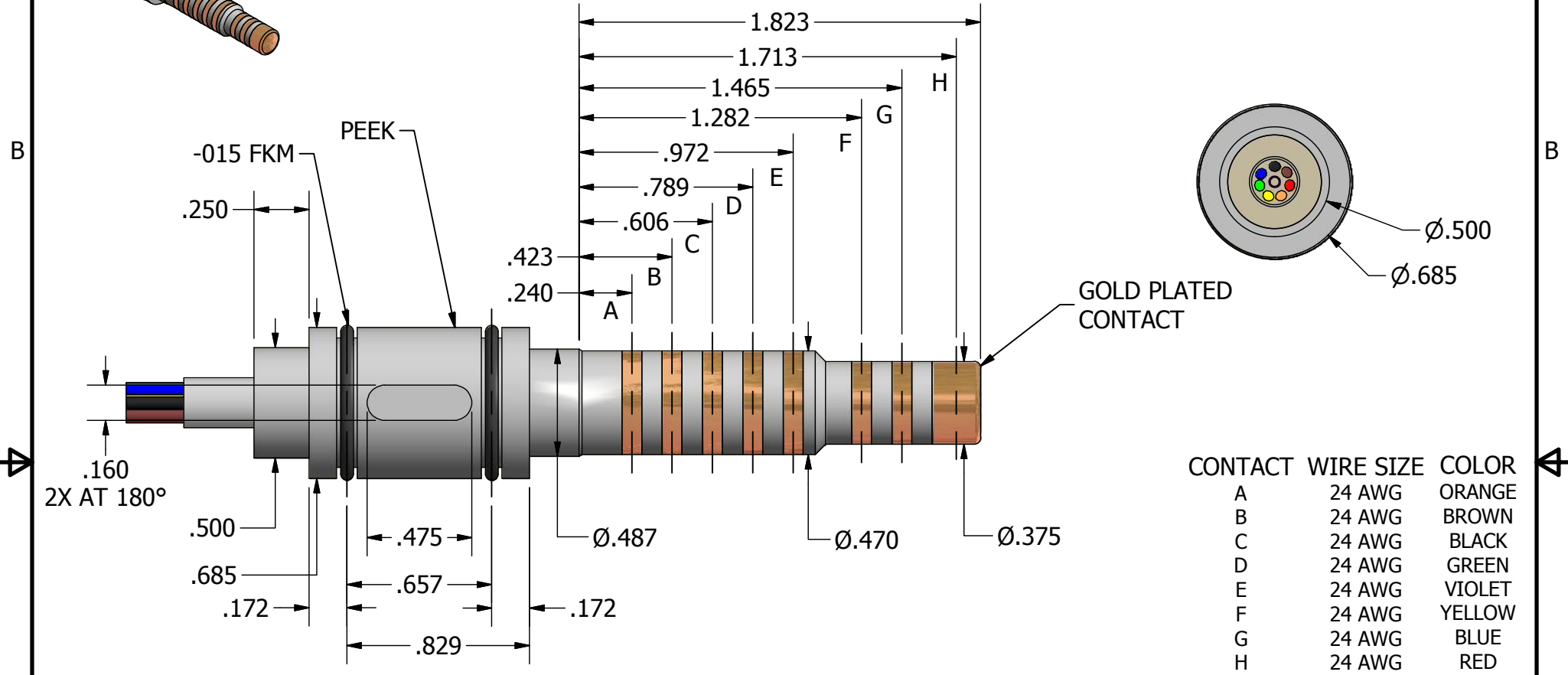

CONTACT	WIRE SIZE	COLOR
A	24 AWG	ORANGE
B	24 AWG	BROWN
C	24 AWG	BLACK
D	24 AWG	GREEN
E	24 AWG	VIOLET
F	24 AWG	YELLOW
G	24 AWG	BLUE
H	24 AWG	RED

WIRING DIAGRAM

- NOTES:
- TEMPERATURE RATING: 392°F (200°C)
 - WIRE LEADS TO BE 24" MINIMUM FLYING LEADS FROM END OF CONNECTOR OR AS DETERMINED BY CUSTOMER.
 - CONTACTS ARE GOLD PLATED PER MIL-G-45204C, TYPE I OR II, GRADE C OR D, CLASS 1 OVER NICKEL PER QQ-N-290A, CLASS 1, GRADE G.

DRAWN SISELT	11/9/2011
CHECKED JSTEELE	11/10/2011
APPROVED PBALCOM	11/10/2011
UNLESS OTHERWISE SPECIFIED: DIMENSIONS ARE IN INCHES [MM] TOLERANCES: ANGULAR: ±.50° TWO PLACE DECIMAL ±.015 THREE PLACE DECIMAL ±.005 FOUR PLACE DECIMAL ±.0005 FILLET: R.032 MAX REMOVE ALL BURRS AND BREAK SHARP EDGES .015 MAX	

TITLE: **ASSEMBLY, 8-CONDUCTOR MALE - STEPPED**

SIZE A	MATERIAL 915-0150-01	DWG NO 915-0150-01 SALES	REV A
-----------	-------------------------	-----------------------------	----------

All rights reserved. This document and the information contained herein are the sole property of Canyon Manufacturing Inc. Any reproduction or distribution in whole or in part without written permission of Canyon Manufacturing Inc. is prohibited.

SHEET 1 OF 1