

REVISION HISTORY			
REV	DESCRIPTION	DATE	APPROVED
C	UPDATE PER 915-0100-02	3/16/2011	
D	ADDED FLYING LEAD MIN LENGTH	8/25/2011	

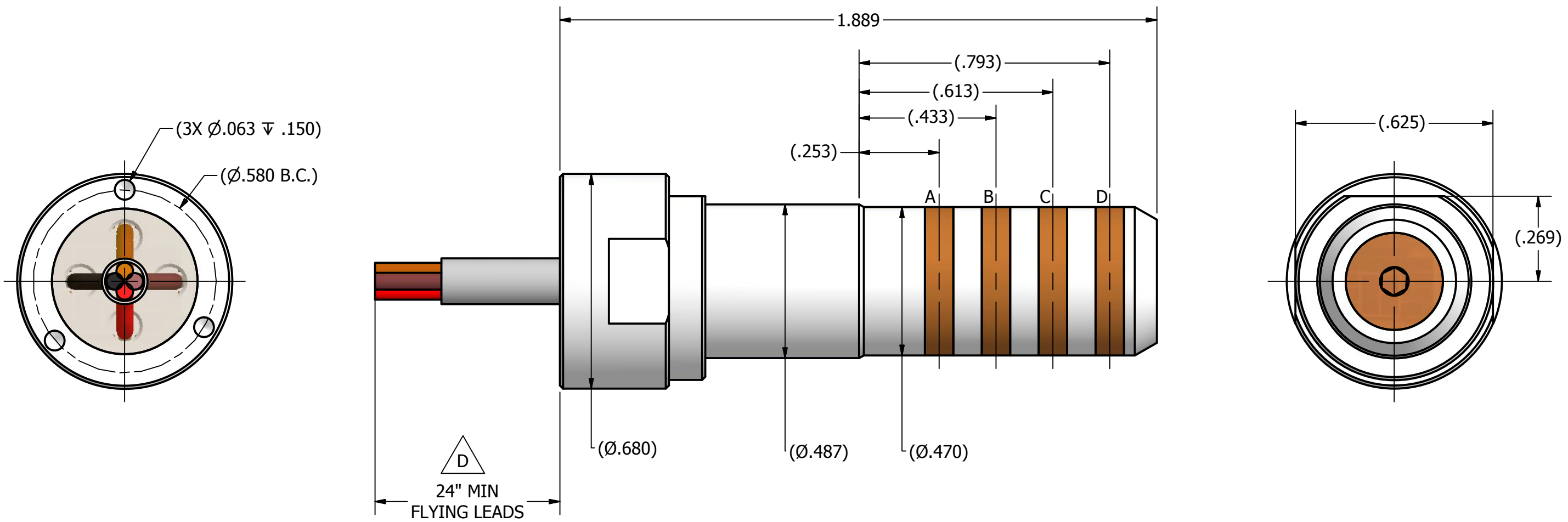

CONTACT	WIRE SIZE	COLOR
A	24 AWG	ORANGE
B	24 AWG	BROWN
C	24 AWG	BLACK
D	24 AWG	RED

WIRING DIAGRAM

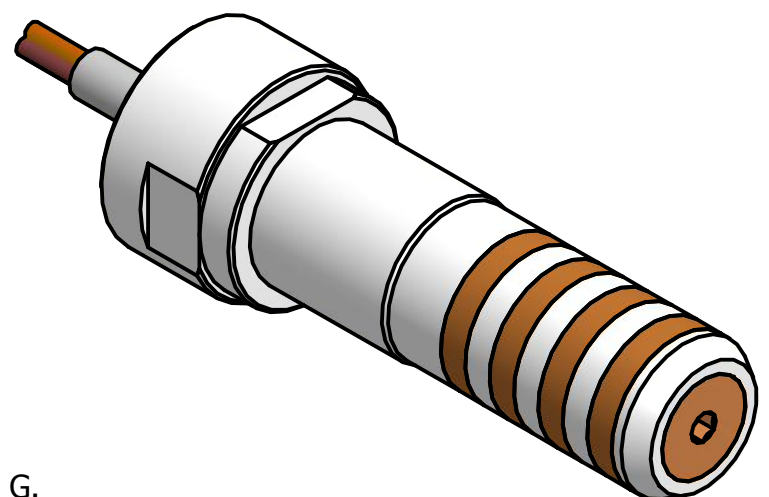

- NOTES:
- TEMPERATURE RATING: 392°F (200°C)
 - WIRE LEADS TO BE 24" MINIMUM FLYING LEADS FROM END OF CONNECTOR OR AS DETERMINED BY CUSTOMER.
 - CONTACTS ARE GOLD PLATED PER MIL-G-45204C, TYPE I OR II, GRADE C OR D, CLASS 1 OVER NICKEL PER QQ-N-290A, CLASS 1, GRADE G.
 - PART NUMBER TO ORDER: 915-0100-01 CURRENT REV.

DRAWN mreaves	8/25/2011
CHECKED	
APPROVED	

UNLESS OTHERWISE SPECIFIED:
 DIMENSIONS ARE IN INCHES [MM]
 TOLERANCES:
 ANGULAR: ±.50°
 TWO PLACE DECIMAL ±.015
 THREE PLACE DECIMAL ±.005
 FOUR PLACE DECIMAL ±.0005
 FILLETS: R.032 MAX
 REMOVE ALL BURRS AND BREAK SHARP EDGES .015 MAX

4-CONDUCTOR MALE IN-LINE CONCENTRIC STAB CONNECTOR			
SIZE	MATERIAL	DWG NO	REV
B	915-0100-01	915-0100-01 SALES	D
All rights reserved. This document and the information contained herein are the sole property of Canyon Manufacturing Inc. Any reproduction or distribution in whole or in part without written permission of Canyon Manufacturing Inc. is prohibited.			
SHEET 1 OF 1			